



Park Hill School District

Building Successful Futures • Each Student • Every Day

2019 Asphalt Bid Package - ADDENDUM #1

May 9, 2019

The following additions/changes/deletions shall be made and incorporated in the subject bid package:

Revision to Sheet 2:

Painted Paving Markings is changed to state new paint shall match existing in type. Existing thermoplastic markings shall be re-applied in matching material. Existing acrylic paint to be re-applied in matching material.

Revision to Sheet 4:

Removal of one (1) steel bollard is added. Saw cut flush with pavement and properly dispose of the bollard.

Revisions to Sheet 5:

The new area inlet piping will connect to the existing curb inlet in the southwest corner of the south parking section.

Replacement of twenty (20) LF of curb and gutter near the curb inlet at the southern extent of resurfacing area "D" is added.

Revisions to Sheet 6:

Patch "D" is widened to 20' x 58'. Patch "E" is eliminated.

Provide alternate pricing for replacement of two (2) sections of the existing directional island along with island re-painting.



Park Hill School District

Building Successful Futures • Each Student • Every Day

Revision to Sheet 7:

Parking lot improvements at Gerner Facility must include multiple phases to maintain access and parking for occupants. Gerner Family Early Education Center is in use year-round.

Revision to Sheet 9:

The quantity of curb and gutter replacement is reduced to 144 LF.

Revision to Sheet 10:

Incorporate new 4-inch perforated PVC piping install with curbing, sidewalk and patchwork “J” and “K” replacements. Connect new piping to existing curb inlet. Include vertical clean-out at T-Junction.



Park Hill School District

2019 PAVEMENT REPAIR PROJECTS ADDENDUM #1 - MAY 9, 2019

SHEET LIST:

- SHEET 1 -- COVER PAGE
- SHEET 2 -- PROJECT REQUIREMENTS

BARRY ROAD CAMPUS

- SHEET 3 -- PARK HILL HIGH SCHOOL EAST
- SHEET 4 -- PARK HILL HIGH SCHOOL WEST
- SHEET 5 -- CENTRAL OFFICE
- SHEET 6 -- AQUATIC CENTER
- SHEET 7 -- GERNER FAMILY EARLY EDUCATION CENTER

OTHER FACILITIES

- SHEET 8 -- GRADEN ELEMENTARY
- SHEET 9 -- HAWTHORN ELEMENTARY
- SHEET 10 -- TIFFANY RIDGE ELEMENTARY
- SHEET 11 -- PARK HILL SOUTH HIGH SCHOOL

BID CLOSING: Wednesday, May 15, 2019 10:00AM CDT

A mandatory pre-bid meeting and walk through of schools will start at Park Hill Central Office, 7703 NW Barry Road on May 7, 2019 at 10:00AM CDT.

Sealed proposals will be received by the Director of Operations at the Support Services office located at 8500 NW River Park Drive, Pillar 116, Parkville, MO 64152

Proposals must be returned on the form(s) provided, with "Bid Proposal - Asphalt / Concrete" clearly on the label. A proposal must consist of all pages of the proposal request including the signature page signed by an authorized representative of the firm. Non-conformance with these instructions may be grounds for rejection of proposal.

Park Hill School District reserves the right to reject any or all proposals and to waive informalities or irregularities in any proposal.

Work may begin Thursday, June 6, 2019 and must be complete by Friday, August 2, 2019.

All work not completed by August 2, 2019 shall result in a \$1,000 per diem penalty to be deducted by the District from final payment.

Prevailing Wages will apply. Current Missouri Division of Labor Standards, Wage and Hour Section 083, Platte County version will apply.

The project is tax except.



PROJECT REQUIREMENTS

Project Safety

Construction equipment and the work area is required to be secured in a manner that protects the public and employees from hazard. The Contractor will be responsible for assuring that physical barriers required to prevent vehicle and pedestrian hazards remain intact throughout the duration of the project. The Contractor is required to conduct operations in a manner that is consistent and compliant with OSHA safety requirements. Contractor to provide all temporary utilities, including toilet, water, electric, etc. No access to the building unless for emergency.

Building Permits, Traffic Permits and Inspections

Contractor will be responsible for obtaining and the cost of all required building permits, storm water permits and plans, traffic permits, water metering and inspection fees associated with this project. All permits must be obtained prior to commencing work.

Public and Private Utilities

Contractor shall contact local agencies to locate underground utilities. Park Hill School District shall be responsible to locate private utilities. Contractor shall protect known utilities, landscaping, curbing, irrigation system components and all existing structures. Should damage occur, contractor is responsible to return each above to their original condition.

Removal of Construction Debris and Materials

Remove and dispose of materials properly per AHJ, OSHA, and EPA regulations. The Contractor will not dispose of any trash or construction materials in property's trash containers. Construction debris, millings and excavated granular, soil or excess materials must be removed from the project site by Contractor daily. Insure no rock or construction material reaches building, landscape, or other areas. Concrete wash out shall be off-site. Broom or blow clean all trash and construction debris at each facility's final completion. Return landscaping and all existing structures to original condition or better.

Warranty

Contractor shall warranty all project materials and workmanship for a minimum of one year from substantial completion. New surfacing shall be warranted from raveling, delamination, potholing or surface cracking for a period of one year. Contractor is responsible to maintain proper drainage and insure no ponding water. Specific concerns regarding warrantability due to existing condition(s) must be brought to the attention of Gateway Pavement Consulting and/or Park Hill School District in advance.

Concrete Curb & Gutter

Concrete curb and gutter to be match existing curbing in style, reveal and width. Thickness to be per plans and details. Place 1/2-inch fiber expansion joints were new curbing abuts existing. Dowel new curbing to existing with three (3) #4 rebar. Place three (3) continuous runs of #4 rebar in new curb and gutter. Expansion joints shall not exceed every 30 LF of curbing run, minimum 1-inch deep tool joints not to exceed every 10 LF of curbing run. Concrete to be minimum 3,500 psi. Back-fill topsoil behind new curb and tamp.

Concrete Sidewalk

Concrete sidewalk to be a minimum of 4-inches thick and reinforced with light welded wire mesh. Place 1/2-inch fiber expansion joints were new concrete abuts existing. Expansion joints shall be placed at sidewalk intersections, at back-side of curbing and not exceed every 50 LF of sidewalk run. Minimum 1-inch deep tool joints to be placed on center and not to exceed the width of the sidewalk. Sidewalks wider than 8'-0" to have longitudinal tool joint at mid-point in width. Concrete to be minimum 3,500 psi. Back-fill topsoil behind new sidewalk and tamp.

Concrete Pavement

Concrete pavement to be a minimum of 6-inches thick and reinforced with heavy welded wire mesh. Place 1/2-inch fiber expansion joints were new concrete abuts existing. Dowel new concrete pavement to existing with #4 rebar not less than every 18-inches on center or per plans. Expansion joints shall not exceed every sixty feet (60') square. Apply cure and seal. As soon as feasible, saw-cut minimum 2-inch deep control joints not to exceed fifteen feet (15') square. Concrete to be minimum 4,000 psi. Do not permit vehicular traffic on concrete pavement until it has sufficiently cured.

HMA Mix Design

Surface course mix to be to be State Design mix with fine graded aggregate. Asphalt wearing surface minimum density should be 92%. Placement of coarse graded surface mix is not allowed. Contractor is responsible to provide Hot Mix Asphalt surface mix design approved for intended use by the MoDOT Specifications. The asphalt surface should be placed per MoDOT Standard Specifications for temperature, jointing and compaction. Contractor shall provide material tickets verifying approved HMA mix delivery.

HMA Installation

Shall be performed in accordance with, and conform to, the most current version of applicable MoDOT Standard Specifications.

Examine the existing base materials to verify that conditions are satisfactory to receive the new paving system. 95% standard compaction must be achieved. Where feasible, proof-roll base materials using heavy, pneumatic-tired rollers to locate areas that may be unstable or that require further compaction. Before proceeding with any installation, notify Gateway Pavement Consulting and / or Park Hill School District of any soil or base areas that are unsuitable to properly support new paving. Install tack coat.

New asphalt surface course shall be a minimum of two inches (2") thick after compaction. Average Density to be 92 percent, but not less than 90 percent nor greater than 96 percent.

Compact areas inaccessible to roller equipment thoroughly, using tamper or other satisfactory method.

Contractor is responsible to provide photographic record that HMA temperature requirements are met, including; minimum surface temperature, HMA placing minimum temperature and HMA compaction completion minimum temperature. Complete compaction before mix temperature cools to 185°F. Contractor will be fully responsible for replacement of and re-application of materials at its cost should photographic record not be provided.

After final rolling, do not permit vehicular traffic on pavement until it has cooled enough not to become marked.

Crack-sealing (Central Office)

Route out all suitable, straight-line cracking in asphalt pavement 1/4-inch wide or greater to form a reservoir for hot applied crack sealant. Thoroughly clean route reservoir with compressed air or other satisfactory method to remove any dust or debris. Seal cracks with Crafcro Parking Lot Sealant (or approved equal) per manufacturer's application specifications. Fill cracking as close to flush as possible; a thin squeegeed band-aid is acceptable.

Seal-coating (Central Office)

Remove oil and grease spots by scrubbing and flushing with water until clean. Clean asphalt surface of all loose dust, dirt, leaves, and any other foreign materials by contractor preferred method.

Seal-coat material to be high quality, polymer modified coal-tar emulsion. Machine apply two (2) layers of seal-coating. First application to be by self-propelled squeegee machine.

Second application to be spray applied. Do not permit vehicular traffic on pavement until sealer has cured enough not to become marked. Sealcoating will require multiple phases to maintain access and parking for occupants.

The central office is in use year-round.

Painted Pavement Markings

Where feasible, allow new surfacing to cure for two to four weeks prior to new painting. New pavement markings to match existing in type. Existing thermoplastic markings to be re-applied to match.

Existing acrylic paint to be re-applied to match. Application with brush or roller is not allowed. Mark the International Handicapped Symbol at indicated parking spaces using a suitable template and pneumatic sprayer. Apply uniformly painted markings of color(s), lengths and widths to match existing with sharp edges and ends.



Park Hill School District

2019 PAVEMENT REPAIR PROJECTS



(314) 295-6747

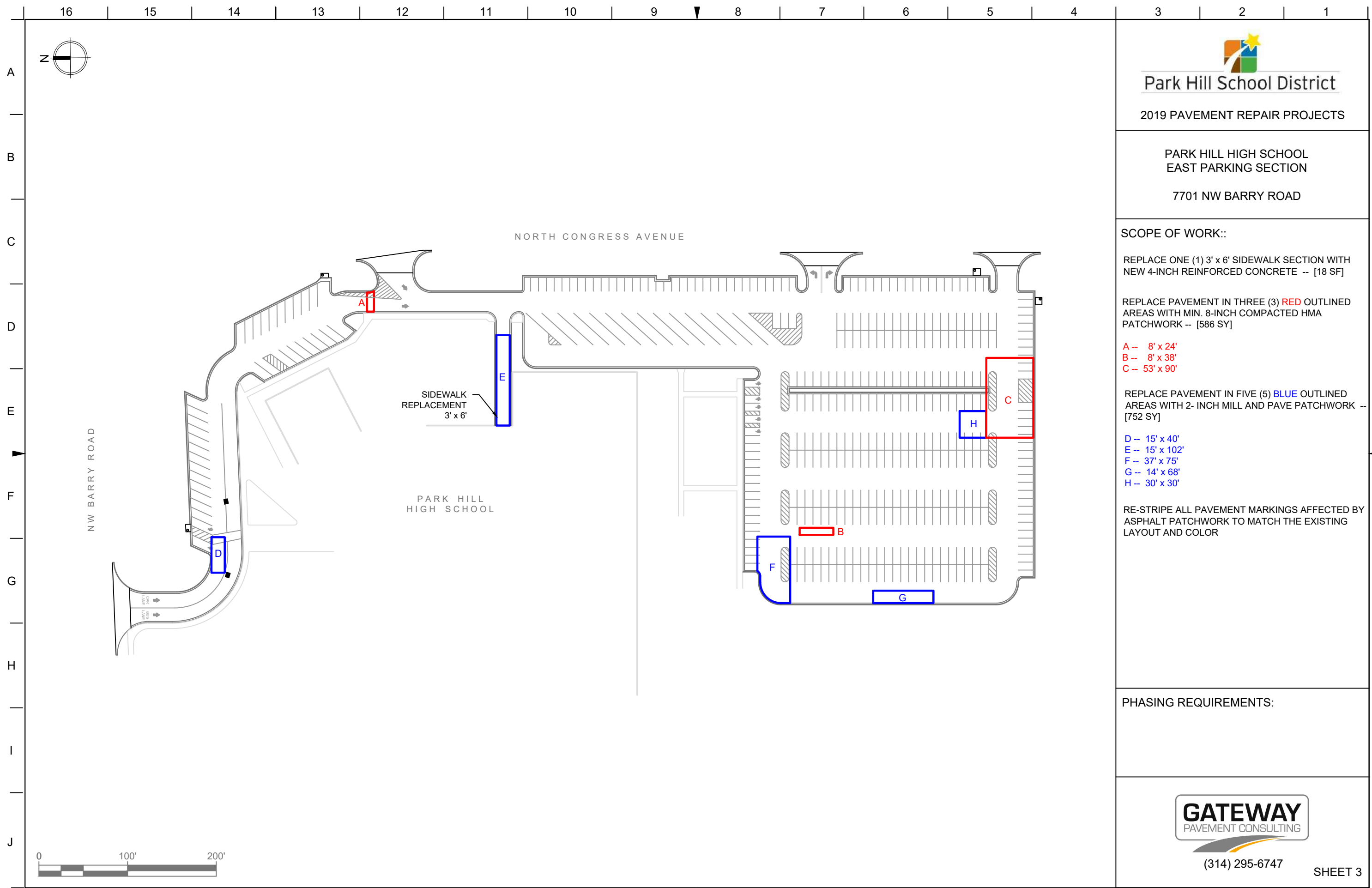

Park Hill School District

2019 PAVEMENT REPAIR PROJECTS

**PARK HILL HIGH SCHOOL
EAST PARKING SECTION**

7701 NW BARRY ROAD

SCOPE OF WORK::

REPLACE ONE (1) 3' x 6' SIDEWALK SECTION WITH NEW 4-INCH REINFORCED CONCRETE -- [18 SF]

REPLACE PAVEMENT IN THREE (3) RED OUTLINED AREAS WITH MIN. 8-INCH COMPACTED HMA PATCHWORK -- [586 SY]

- A -- 8' x 24'
- B -- 8' x 38'
- C -- 53' x 90'

REPLACE PAVEMENT IN FIVE (5) BLUE OUTLINED AREAS WITH 2- INCH MILL AND PAVE PATCHWORK -- [752 SY]

- D -- 15' x 40'
- E -- 15' x 102'
- F -- 37' x 75'
- G -- 14' x 68'
- H -- 30' x 30'

RE-STRIPE ALL PAVEMENT MARKINGS AFFECTED BY ASPHALT PATCHWORK TO MATCH THE EXISTING LAYOUT AND COLOR

PHASING REQUIREMENTS:



(314) 295-6747

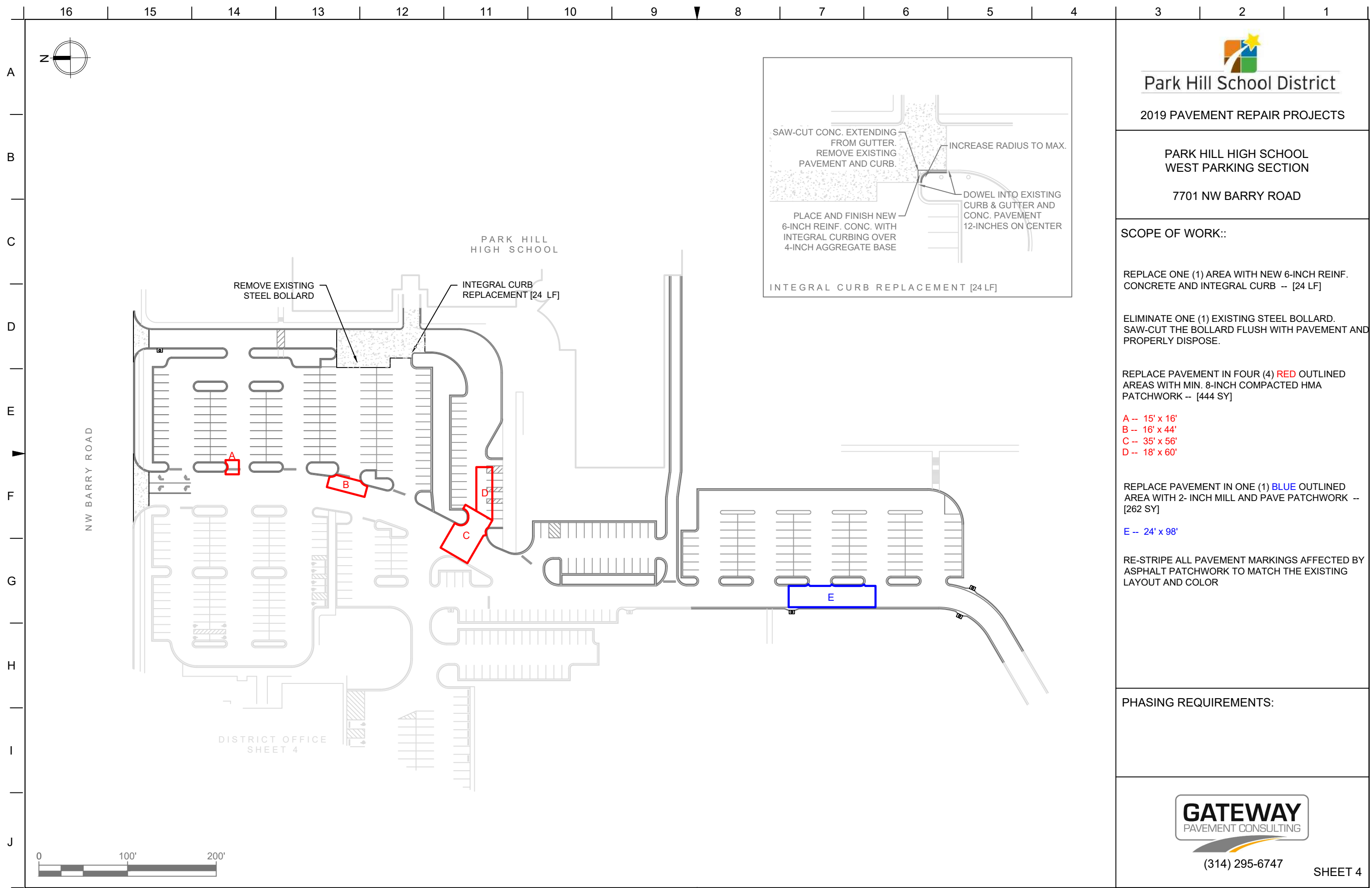

Park Hill School District

2019 PAVEMENT REPAIR PROJECTS

**PARK HILL HIGH SCHOOL
WEST PARKING SECTION**

7701 NW BARRY ROAD

SCOPE OF WORK::

REPLACE ONE (1) AREA WITH NEW 6-INCH REINF. CONCRETE AND INTEGRAL CURB -- [24 LF]

ELIMINATE ONE (1) EXISTING STEEL BOLLARD. SAW-CUT THE BOLLARD FLUSH WITH PAVEMENT AND PROPERLY DISPOSE.

REPLACE PAVEMENT IN FOUR (4) RED OUTLINED AREAS WITH MIN. 8-INCH COMPACTED HMA PATCHWORK -- [444 SY]

- A -- 15' x 16'
- B -- 16' x 44'
- C -- 35' x 56'
- D -- 18' x 60'

REPLACE PAVEMENT IN ONE (1) BLUE OUTLINED AREA WITH 2- INCH MILL AND PAVE PATCHWORK -- [262 SY]

- E -- 24' x 98'

RE-STRIPE ALL PAVEMENT MARKINGS AFFECTED BY ASPHALT PATCHWORK TO MATCH THE EXISTING LAYOUT AND COLOR

PHASING REQUIREMENTS:



(314) 295-6747

16 15 14 13 12 11 10 9 8 7 6 5 4 3 2 1

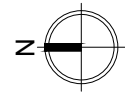

A
B
C
D
E
F
G
H
I
J

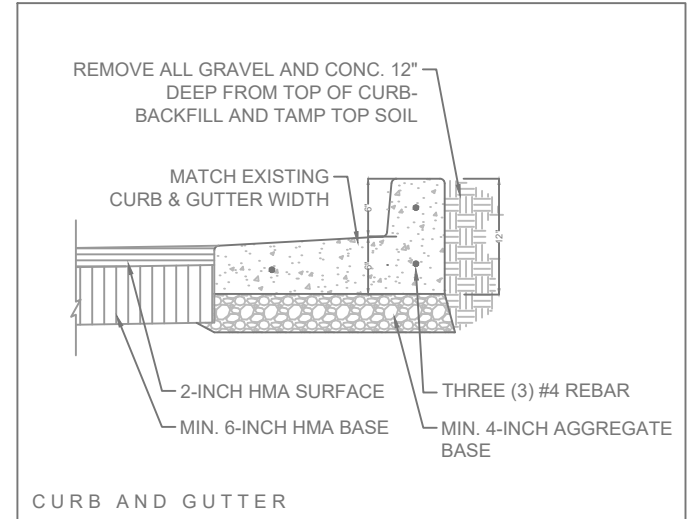

PARK HILL HIGH SCHOOL
WEST SECTION SHEET 3

NW BARRY ROAD

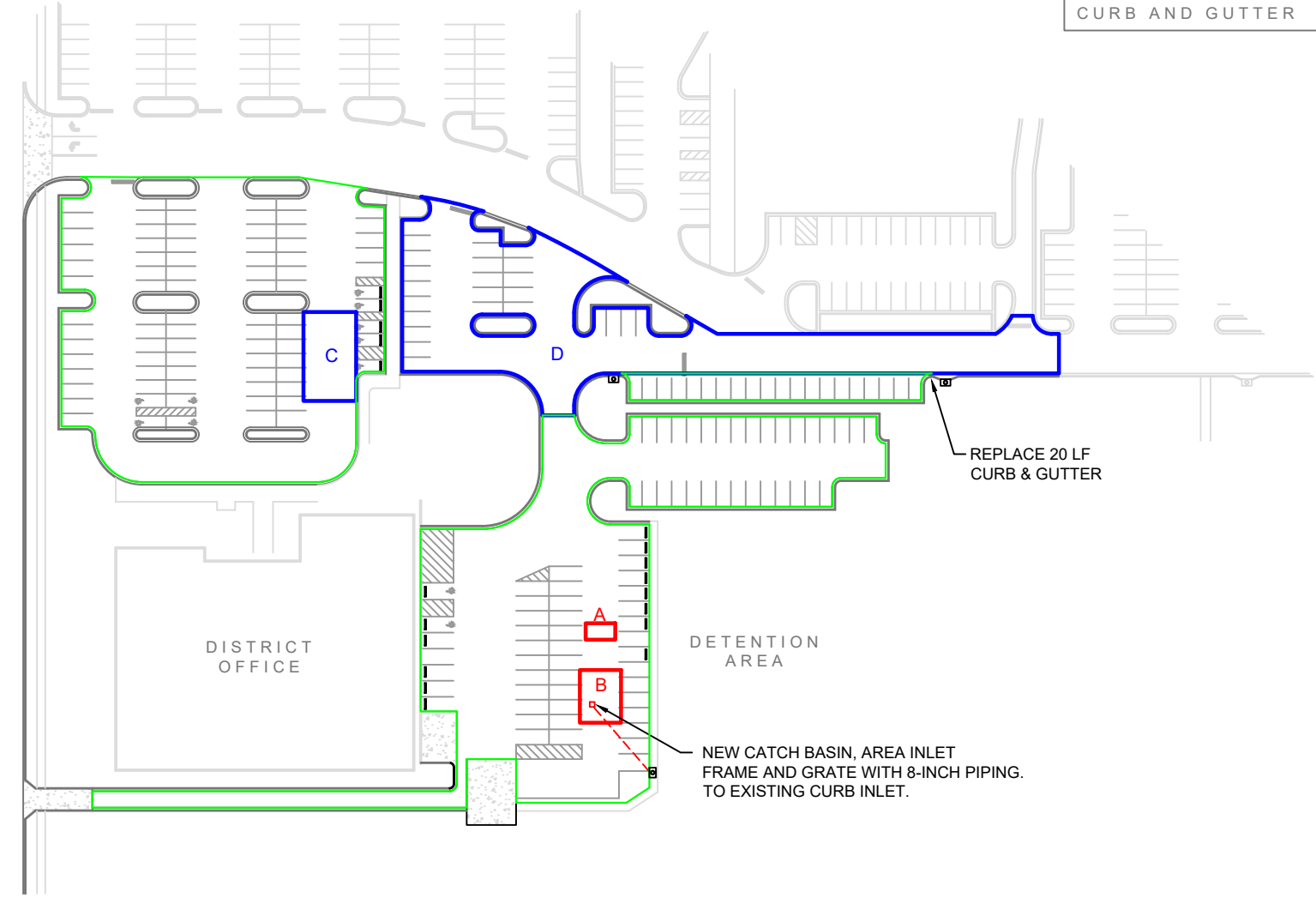

2019 PAVEMENT REPAIR PROJECTS

CENTRAL OFFICE
7703 NW BARRY ROAD

SCOPE OF WORK::

REMOVE AND REPLACE CONCRETE CURB AND GUTTER IN ONE (1) AREA -- [20 LF]

REPLACE PAVEMENT IN TWO (2) **RED** OUTLINED AREAS WITH MIN. 8-INCH COMPACTED HMA PATCHWORK -- [109 SY]

A -- 10' x 18'
B -- 25' x 32'

WITHIN "PATCH B" PROVIDE AND INSTALL NEW PRE-CAST CONCRETE CATCH BASIN, AREA INLET FRAME AND GRATE, AND 8-INCH SCHEDULE 40 PVC PIPE TO EXISTING CURB INLET.

RESURFACE PAVEMENT IN TWO (2) **BLUE** OUTLINED AREAS WITH 2- INCH HMA MILL AND PAVE -- [2,292 SY]

C -- 32' x 54'
D -- 2,100 SY

WITHIN RESURFACING AREA "D", INCLUDE 300 SY OF 6-INCH HMA BASE REPAIR FOLLOWING MILLING OPERATIONS.

IN GREEN OUTLINED AREAS, PROPERLY PREPARE SUITABLE ASPHALT SURFACE CRACKING 1/4-INCH WIDE OR GREATER AND SEAL WITH HOT APPLIED SEALANT. [INCLUDE 2,500 LF OF CRACK SEALING.]

ALSO IN GREEN OUTLINED AREAS, PROPERLY PREPARE ASPHALT SURFACE AND MACHINE APPLY TWO (2) COATS OF POLYMER MODIFIED COAL-TAR EMULSION SEALCOAT. [INCLUDE 7,900 SY OF SEAL-COATING.]

RE-STRIPE ALL PAVEMENT MARKINGS AND ANY PAINTED CURB, LIGHT BASES OR BOLLARDS TO MATCH THE EXISTING LAYOUT AND COLOR.

PHASING REQUIREMENTS:

PARKING LOT IMPROVEMENTS AT THIS FACILITY MUST INCLUDE MULTIPLE PHASES TO MAINTAIN ACCESS AND PARKING FOR OCCUPANTS. THE CENTRAL OFFICE IS IN USE YEAR-ROUND.

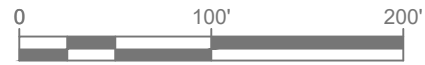

(314) 295-6747 SHEET 5

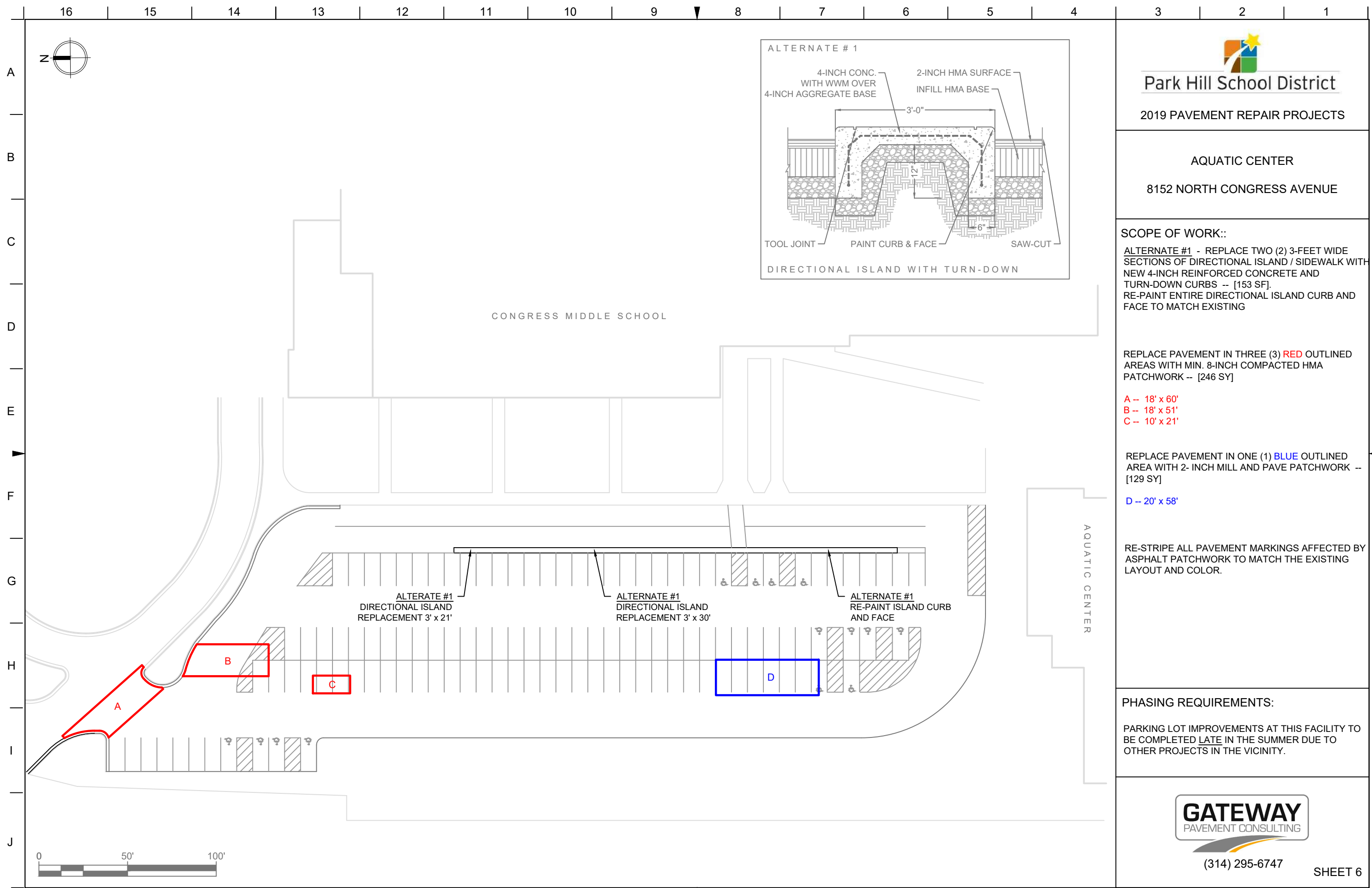

Park Hill School District

2019 PAVEMENT REPAIR PROJECTS

AQUATIC CENTER

8152 NORTH CONGRESS AVENUE

SCOPE OF WORK::

ALTERNATE #1 - REPLACE TWO (2) 3-FEET WIDE SECTIONS OF DIRECTIONAL ISLAND / SIDEWALK WITH NEW 4-INCH REINFORCED CONCRETE AND TURN-DOWN CURBS -- [153 SF].
RE-PAINT ENTIRE DIRECTIONAL ISLAND CURB AND FACE TO MATCH EXISTING

REPLACE PAVEMENT IN THREE (3) **RED** OUTLINED AREAS WITH MIN. 8-INCH COMPACTED HMA PATCHWORK -- [246 SY]

- A -- 18' x 60'
- B -- 18' x 51'
- C -- 10' x 21'

REPLACE PAVEMENT IN ONE (1) **BLUE** OUTLINED AREA WITH 2- INCH MILL AND PAVE PATCHWORK -- [129 SY]

- D -- 20' x 58'

RE-STRIPE ALL PAVEMENT MARKINGS AFFECTED BY ASPHALT PATCHWORK TO MATCH THE EXISTING LAYOUT AND COLOR.

PHASING REQUIREMENTS:

PARKING LOT IMPROVEMENTS AT THIS FACILITY TO BE COMPLETED **LATE** IN THE SUMMER DUE TO OTHER PROJECTS IN THE VICINITY.



(314) 295-6747

16 | 15 | 14 | 13 | 12 | 11 | 10 | 9 | 8 | 7 | 6 | 5 | 4 | 3 | 2 | 1

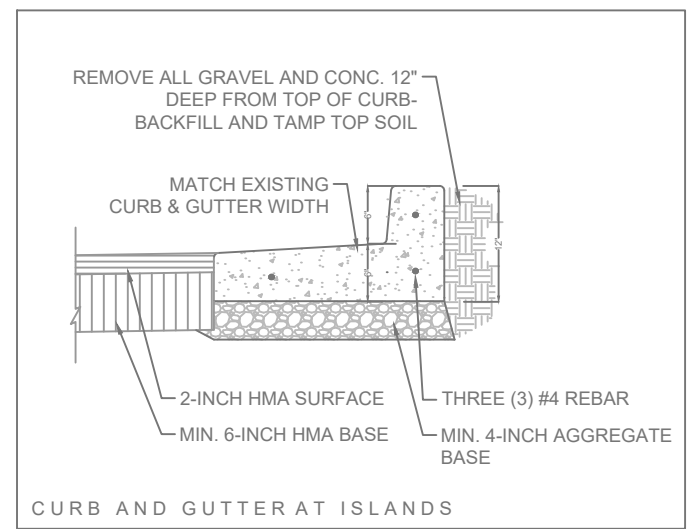
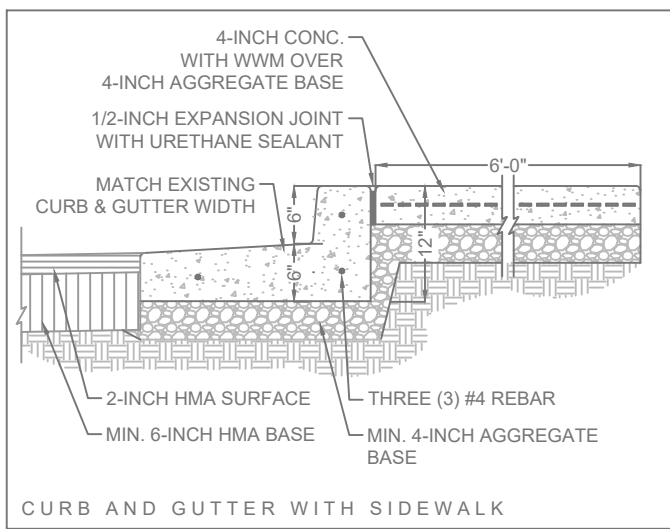
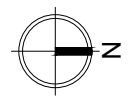

Park Hill School District

2019 PAVEMENT REPAIR PROJECTS

GERNER FAMILY EARLY EDUCATION

8100 NORTH CONGRESS AVENUE

SCOPE OF WORK::

REMOVE AND REPLACE CONCRETE CURB AND GUTTER IN FOUR (4) AREAS -- [196 LF]

REPLACE ONE (1) 6' x 52' SIDEWALK SECTION WITH NEW 4-INCH REINFORCED CONCRETE -- [312 SF]

REPLACE PAVEMENT IN ONE (1) RED OUTLINED AREA WITH MIN. 8-INCH COMPACTED HMA PATCHWORK -- [56 SY]

A -- 20' x 25'

RESURFACE PAVEMENT IN THREE (3) BLUE OUTLINED AREAS WITH PROFILE MILLING AND MIN. 2-INCH HMA PATCHWORK -- [1,330 SY]. THE INTENT OF RESURFACING AND CURB/SIDEWALK REPLACEMENT IS TO REMEDIATE STANDING WATER CONDITIONS.

B -- 600 SY

C -- 550 SY

D -- 180 SY

WITHIN RESURFACING AREAS "B, C, & D", INCLUDE A TOTAL OF 300 SY OF 6-INCH HMA BASE REPAIR FOLLOWING MILLING OPERATIONS.

RE-STRIPE ALL PAVEMENT MARKINGS AFFECTED BY ASPHALT PATCHWORK TO MATCH THE EXISTING LAYOUT AND COLOR.

PHASING REQUIREMENTS:

PARKING LOT IMPROVEMENTS AT THIS FACILITY MUST INCLUDE MULTIPLE PHASES TO MAINTAIN ACCESS AND PARKING FOR OCCUPANTS. THIS FACILITY IS IN USE YEAR-ROUND.



(314) 295-6747

SHEET 7

A
B
C
D
E
F
G
H
I
J

NW 79TH TERRACE

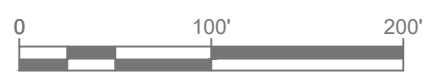
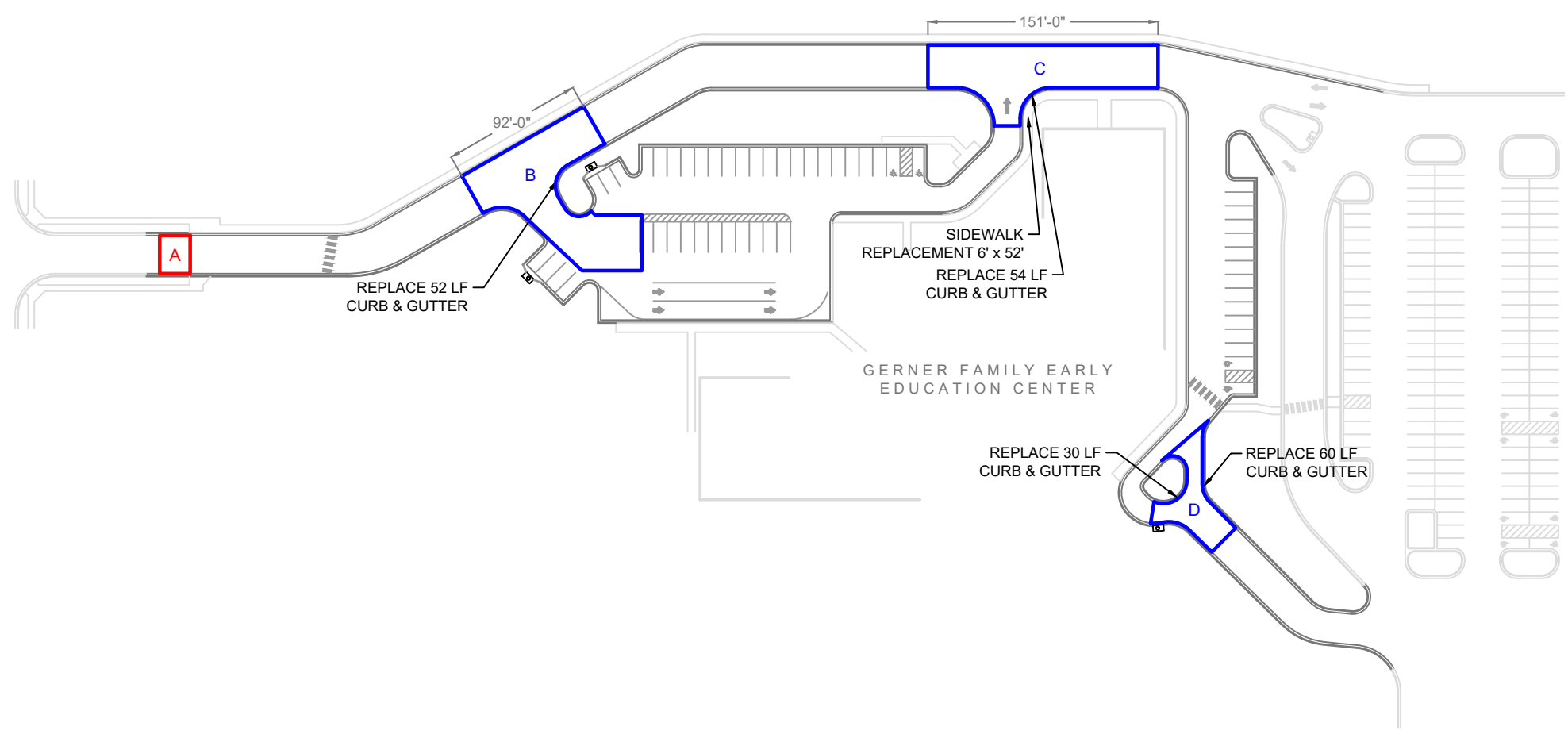

16 | 15 | 14 | 13 | 12 | 11 | 10 | 9 | 8 | 7 | 6 | 5 | 4 | 3 | 2 | 1

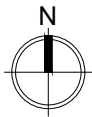

A
B
C
D
E
F
G
H
I
J

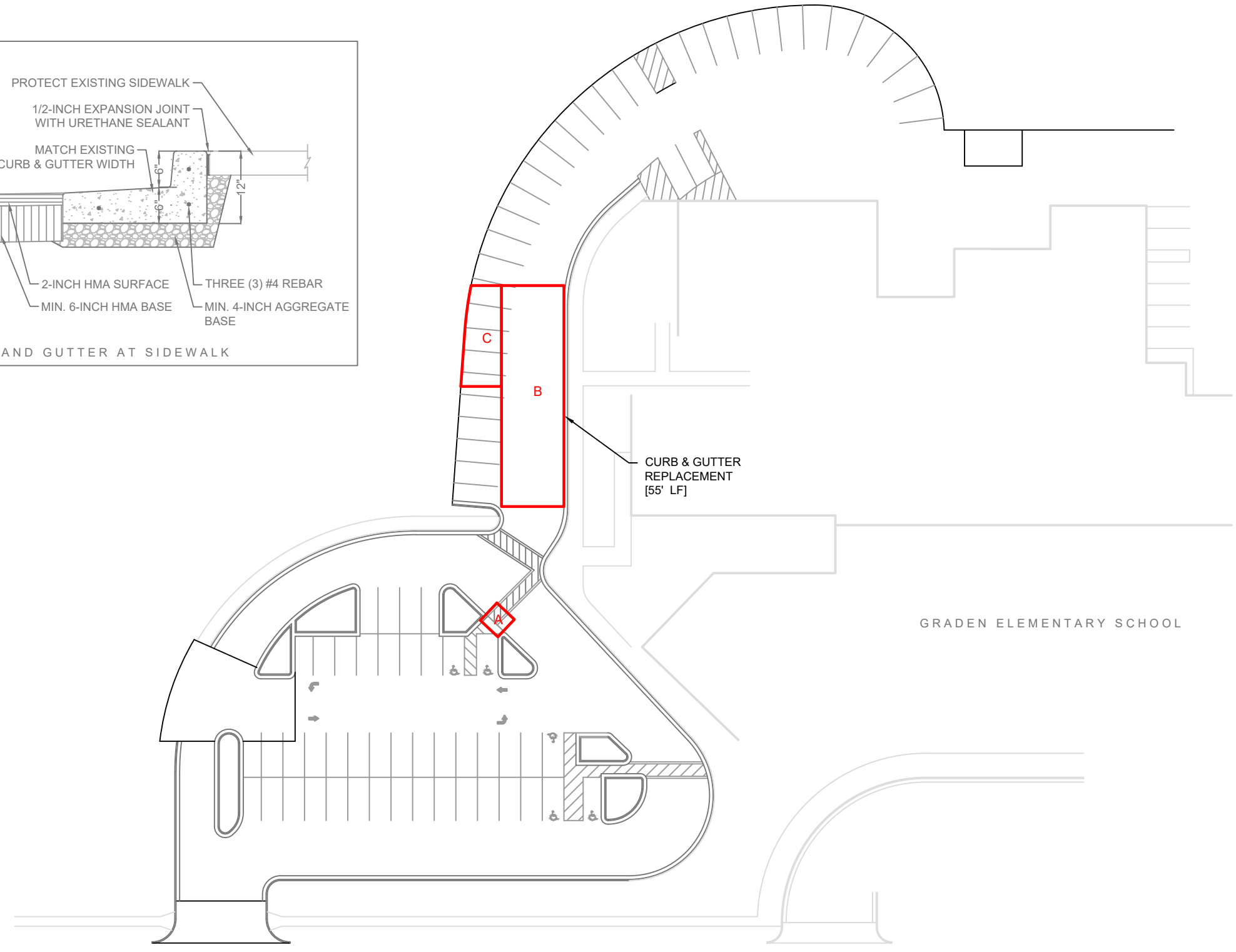
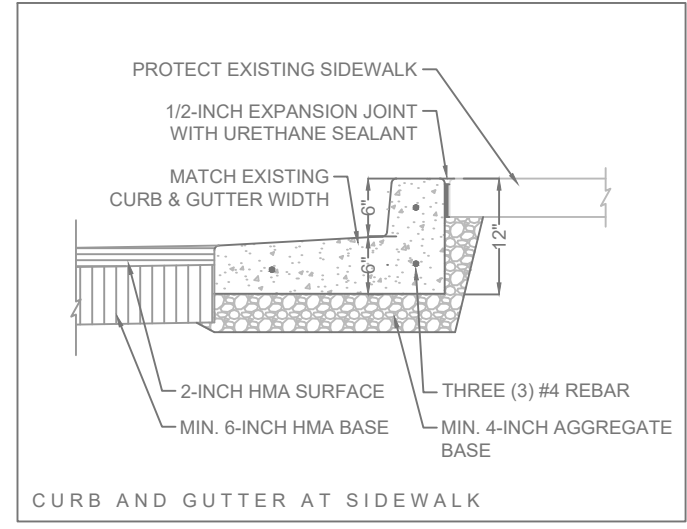

Park Hill School District

2019 PAVEMENT REPAIR PROJECTS

GRADEN ELEMENTARY

8804 NW 45 HIGHWAY, PARKVILLE

SCOPE OF WORK::

REPLACE ONE (1) SECTION OF CONCRETE CURB
NEW REINFORCED CONCRETE CURB AND GUTTER -- [55 LF]

REPLACE PAVEMENT IN THREE (3) RED OUTLINED
AREAS WITH MIN. 8-INCH COMPACTED HMA
PATCHWORK -- [362 SY]

- A -- 10' x 10'
- B -- 26' x 92'
- C -- 18' x 42'

RE-STRIPE ALL PAVEMENT MARKINGS AFFECTED BY
ASPHALT PATCHWORK TO MATCH THE EXISTING
LAYOUT AND COLOR

PHASING REQUIREMENTS:

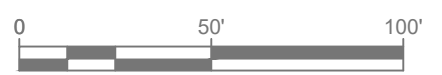

(314) 295-6747

16 | 15 | 14 | 13 | 12 | 11 | 10 | 9 | 8 | 7 | 6 | 5 | 4 | 3 | 2 | 1



A
B
C
D
E
F
G
H
I
J

NORTH CHARITON AVENUE

HAWTHORN ELEMENTARY SCHOOL

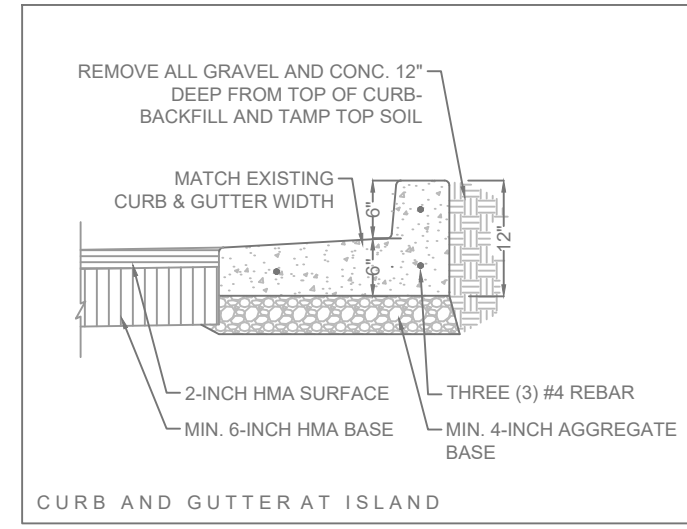
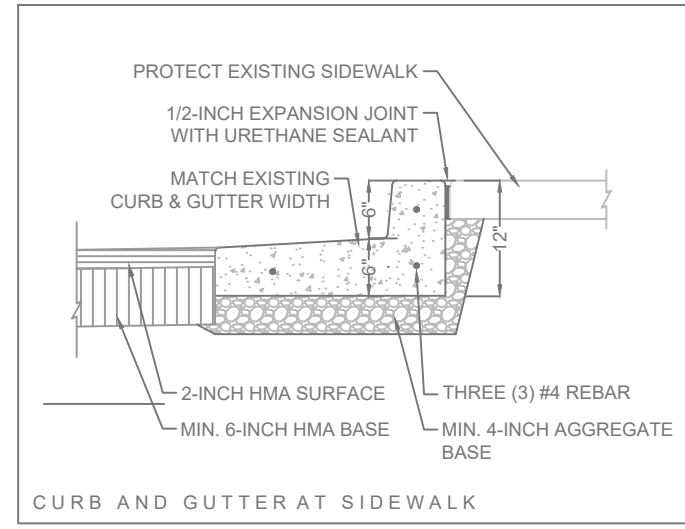

REPLACE 10 LF CURB & GUTTER [20 LF TOTAL]

REPLACE 10 LF CURB & GUTTER

REPLACE 50 LF CURB & GUTTER - [ELEVATE NEW CURBING TO PROPERLY SHED STORMWATER]

REPLACE 31 LF CURB & GUTTER

REPLACE 8 LF CURB & GUTTER

SIDEWALK REPLACEMENT 5' x 10'

REPLACE 15 LF CURB & GUTTER

REPLACE 10 LF CURB & GUTTER

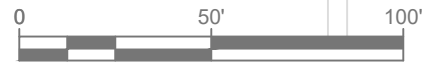

2019 PAVEMENT REPAIR PROJECTS

HAWTHORN ELEMENTARY
8200 NORTH CHARITON AVENUE

SCOPE OF WORK::

REMOVE AND REPLACE CONCRETE CURB AND GUTTER IN EIGHT (8) AREAS -- [144 LF]

REPLACE ONE (1) 5' x 10' SIDEWALK SECTION WITH NEW 4-INCH REINFORCED CONCRETE -- [50 SF]

REPLACE PAVEMENT IN FIVE (5) RED OUTLINED AREAS WITH MIN. 8-INCH COMPACTED HMA PATCHWORK -- [408 SY]

- A -- 13' x 38'
- B -- 22' x 48'
- C -- 24' x 32'
- D -- 14' x 51'
- E -- 20' x 31'

RE-STRIPE ALL PAVEMENT MARKINGS AFFECTED BY ASPHALT PATCHWORK TO MATCH THE EXISTING LAYOUT AND COLOR

PHASING REQUIREMENTS:



(314) 295-6747

16 | 15 | 14 | 13 | 12 | 11 | 10 | 9 | 8 | 7 | 6 | 5 | 4 | 3 | 2 | 1

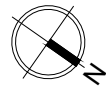

A
B
C
D
E
F
G
H
I
J

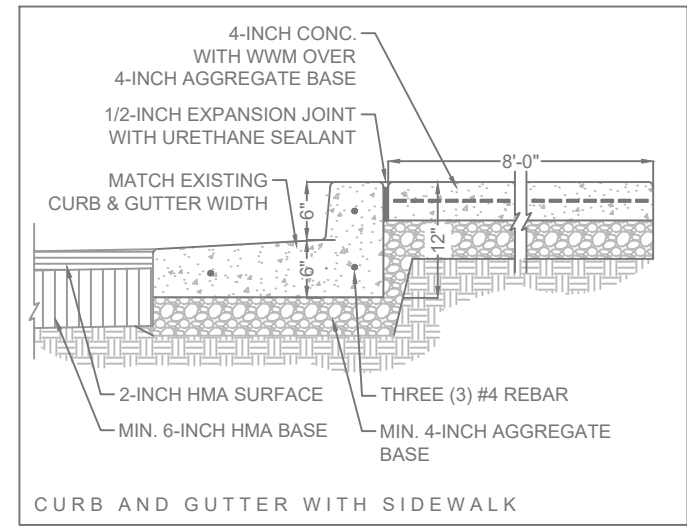

2019 PAVEMENT REPAIR PROJECTS

TIFFANY RIDGE ELEMENTARY
5301 NW OLD TIFFANY SPRINGS ROAD

SCOPE OF WORK::

REMOVE AND REPLACE CONCRETE CURB AND GUTTER IN ONE (1) AREA -- [43 LF]

REPLACE ONE (1) 8' x 44' SIDEWALK SECTION WITH NEW 4-INCH REINFORCED CONCRETE -- [352 SF]

INCORPORATE NEW PERFORATED PIPE INSTALL WITH CURBING, SIDEWALK AND PATCHWORK "J" AND "K" REPLACEMENTS.

REPLACE PAVEMENT IN ELEVEN (11) RED OUTLINED AREAS WITH MIN. 8-INCH COMPACTED HMA PATCHWORK -- [864 SY]

- A -- 14' x 27'
- B -- 16' x 36'
- C -- 15' x 33'
- D -- 27' x 31'
- E -- 29' x 59'
- F -- 24' x 34'
- G -- 16' x 35'
- H -- 10' x 27'
- I -- 24' x 52'
- J -- 10' x 13'
- K -- 14' x 52'

RE-STRIPE ALL PAVEMENT MARKINGS AFFECTED BY ASPHALT PATCHWORK TO MATCH THE EXISTING LAYOUT AND COLOR

PHASING REQUIREMENTS:

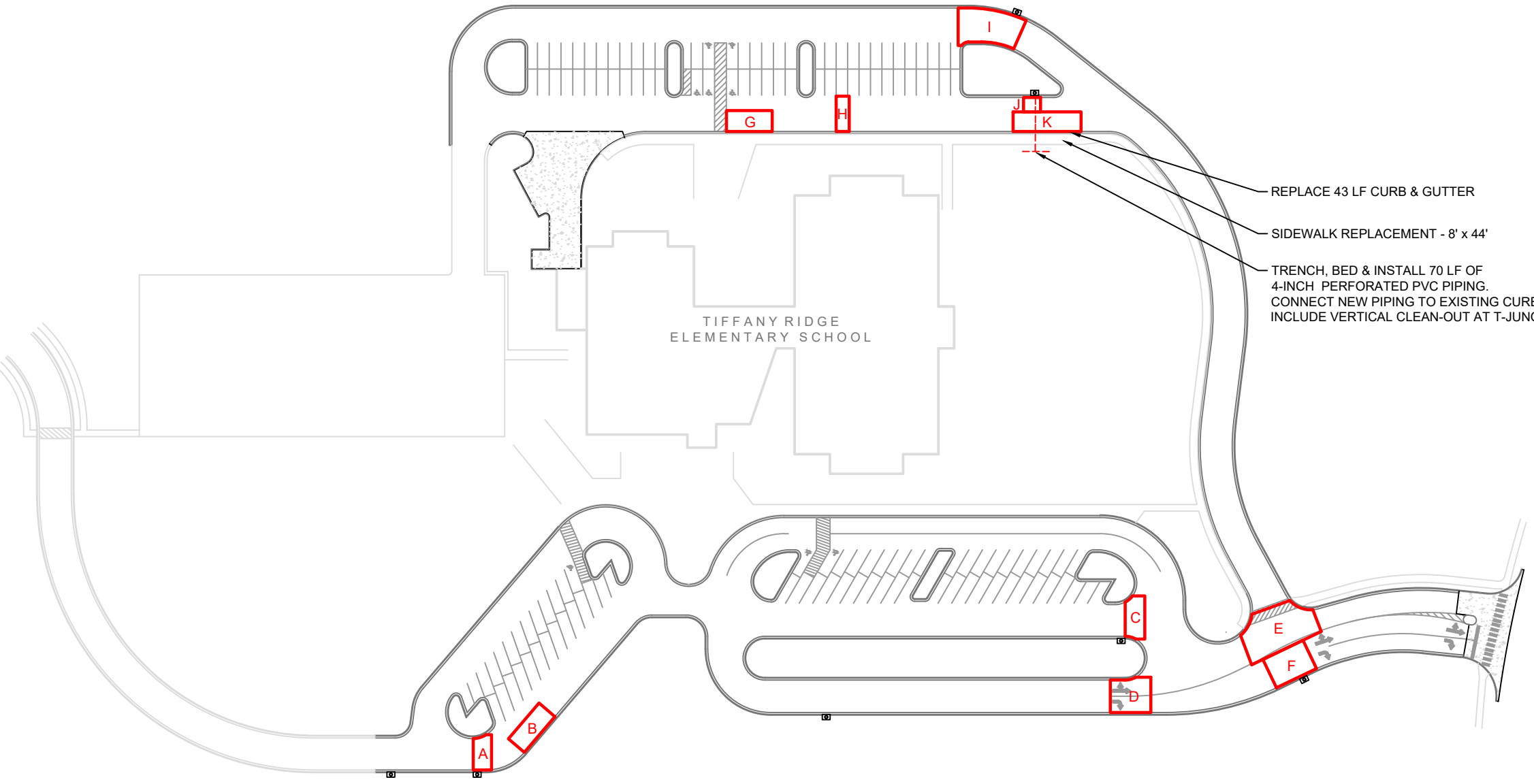

- REPLACE 43 LF CURB & GUTTER
- SIDEWALK REPLACEMENT - 8' x 44'
- TRENCH, BED & INSTALL 70 LF OF 4-INCH PERFORATED PVC PIPING. CONNECT NEW PIPING TO EXISTING CURB INLET. INCLUDE VERTICAL CLEAN-OUT AT T-JUNCTION.

NW OLD TIFFANY SPRINGS ROAD

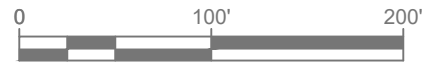

(314) 295-6747

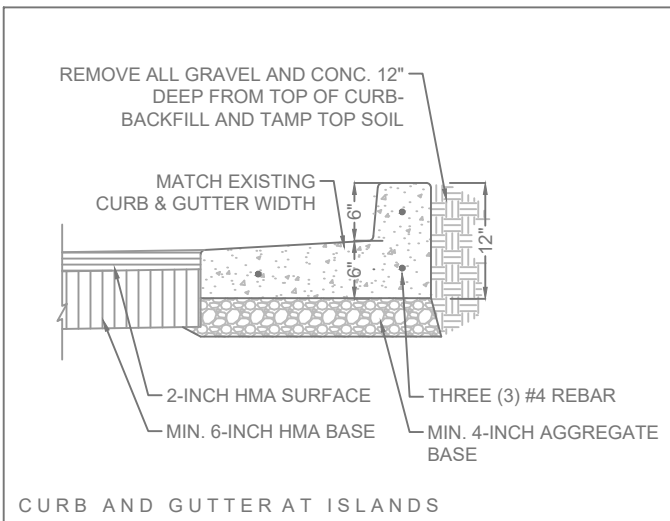
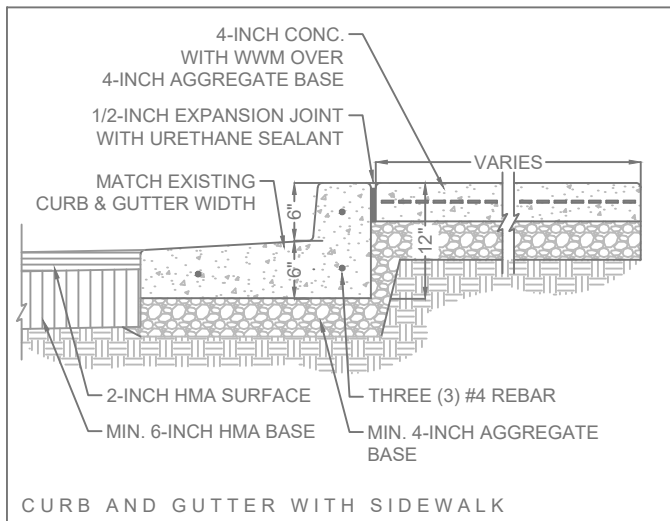
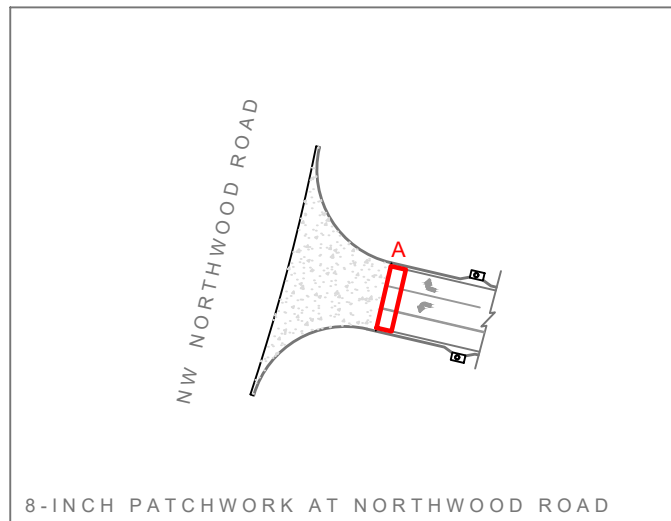
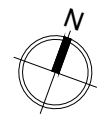

2019 PAVEMENT REPAIR PROJECTS

PARK HILL SOUTH HIGH SCHOOL
4500 NW RIVER PARK DRIVE, RIVERSIDE

SCOPE OF WORK::

REMOVE AND REPLACE CONCRETE CURB AND GUTTER IN TWO (2) AREAS -- [144 LF]

REPLACE THREE (3) SIDEWALK SECTIONS WITH NEW 4-INCH REINFORCED CONCRETE -- [584 SF]

REPLACE PAVEMENT IN ONE (1) RED OUTLINED AREA WITH MIN. 8-INCH COMPACTED HMA PATCHWORK -- [30 SY]

A -- 8' x 33'

RESURFACE PAVEMENT IN TWO (2) BLUE OUTLINED AREAS WITH PROFILE MILLING AND MIN. 2-INCH HMA PATCHWORK -- [1,080 SY]. THE INTENT OF RESURFACING AND CURB/SIDEWALK REPLACEMENT IS TO REMEDIATE STANDING WATER CONDITIONS.

B -- 750 SY
C -- 330 SY

WITHIN RESURFACING AREAS "B & C", INCLUDE A TOTAL OF 200 SY OF 6-INCH HMA BASE REPAIR FOLLOWING MILLING OPERATIONS.

RE-STRIPE ALL PAVEMENT MARKINGS AFFECTED BY ASPHALT PATCHWORK TO MATCH THE EXISTING LAYOUT AND COLOR.

PHASING REQUIREMENTS:

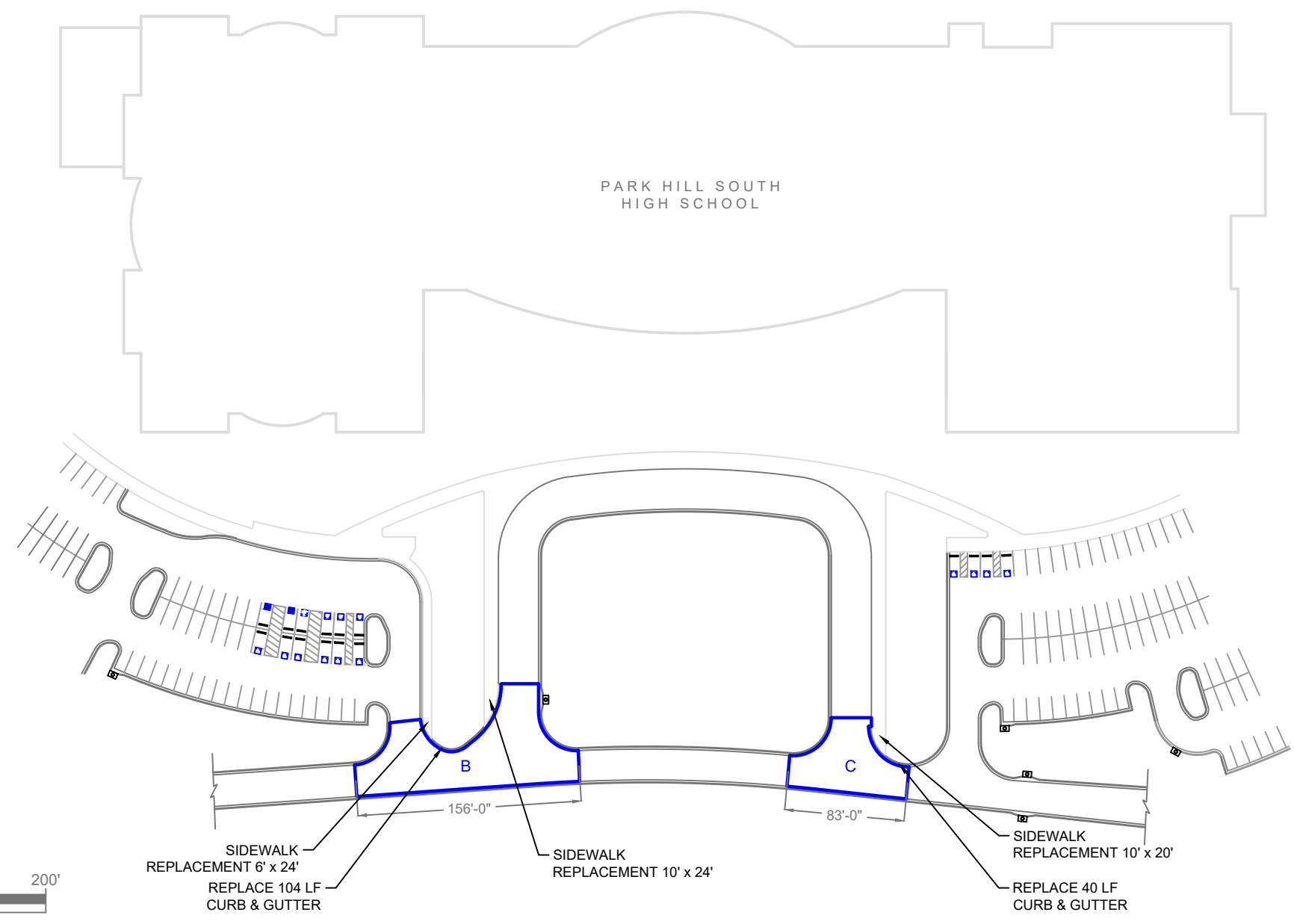

(314) 295-6747

BID FORM – 2019 PAVEMENT REPAIR PROJECTS

Package 1: Barry Road Campus

Barry Road Campus:	
Park Hill School East	\$ _____
Park Hill School West	\$ _____
District Office	\$ _____
Aquatic Center	\$ _____
Gerner Family Early Education	\$ _____

Total Package 1 \$ _____

Alternate 1 – Aquatic Center Island \$ _____

This **work is to be completed between June 6 and August 2, 2019.**

All work not completed by August 2, 2019 shall result in a \$1,000.00 per diem penalty to be deducted by the District from final payment.

Prices as bid on this form shall include total dollar amounts to cover work as specified, including labor, materials, overhead and profit.

COMPANY _____

ADDRESS _____

PHONE _____ FAX _____

EMAIL _____

PRINT NAME _____

SIGNATURE _____ Date: _____

BID FORM – 2019 PAVEMENT REPAIR PROJECTS

Package 2: Other Facilities

Other Facilities:	
Graden Elementary	\$ _____
Hawthorn Elementary	\$ _____
Tiffany Ridge Elementary	\$ _____
Park Hill South High School	\$ _____

Total Package 2 \$ _____

This **work is to be completed between June 6 and August 2, 2019.**

All work not completed by August 2, 2019 shall result in a \$1,000.00 per diem penalty to be deducted by the District from final payment.

Prices as bid on this form shall include total dollar amounts to cover work as specified, including labor, materials, overhead and profit.

COMPANY _____

ADDRESS _____

PHONE _____ FAX _____

EMAIL _____

PRINT NAME _____

SIGNATURE _____ Date: _____

BID FORM – 2019 PAVEMENT REPAIR PROJECT

To include Bid Package 1 and 2

Total Combination \$ _____

This **work is to be completed between June 6 and August 2, 2019.**

All work not completed by August 2, 2019 shall result in a \$1,000.00 per diem penalty to be deducted by the District from final payment.

Prices as bid on this form shall include total dollar amounts to cover work as specified, including labor, materials, overhead and profit.

UNIT PRICING:

- 2" Mill/Overlay Asphalt per sq. yard \$ _____
- 8" Asphalt Replacement per sq. yard \$ _____
- 4" Concrete Sidewalk per sq. ft. \$ _____
- Concrete Curb and Gutter per linear ft. \$ _____
- Seal Coat per sq. yard \$ _____
- Crack fill per linear ft. \$ _____
- Undercutting per 3/4" minus gravel per Ton \$ _____

COMPANY _____

ADDRESS _____

PHONE _____ FAX _____

EMAIL _____

PRINT NAME _____

SIGNATURE _____ Date: _____